KAMCAP



KAMCAP

KAMCAP

▲ 5.5V1.0F
▲ 5.5V1.0F
▲ 5.5V1.0F

KAMCAP ▲
85°C ▲
KAMCAP ▲ DXXXX

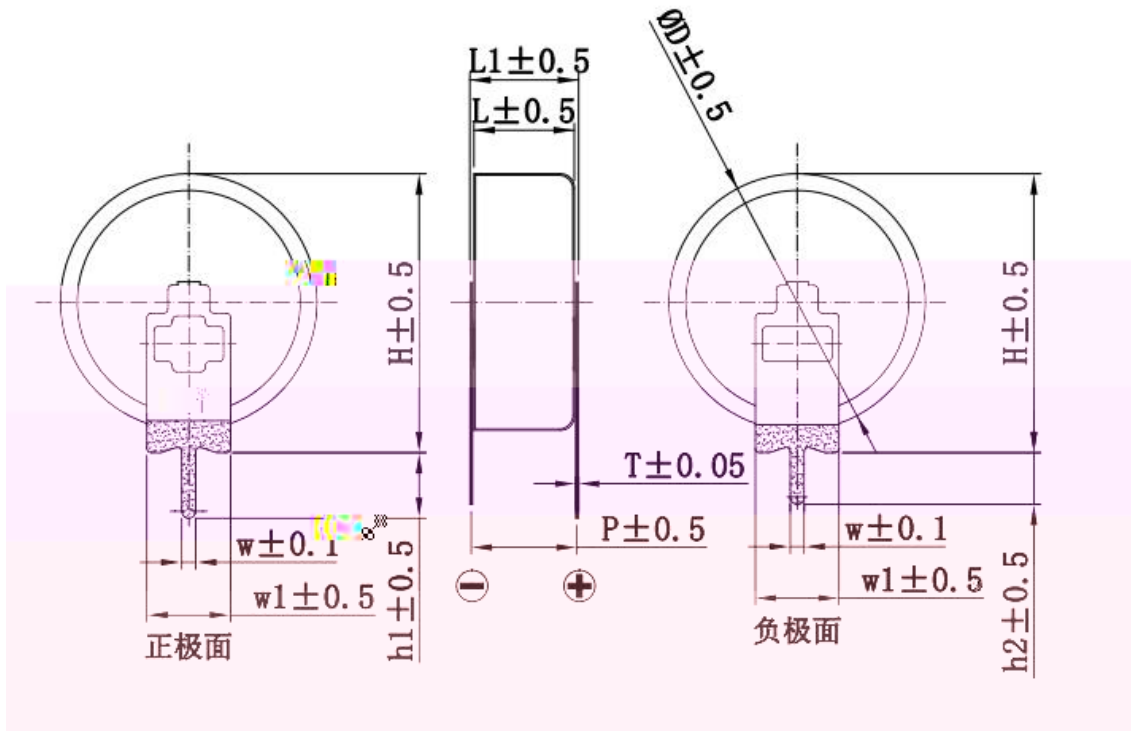

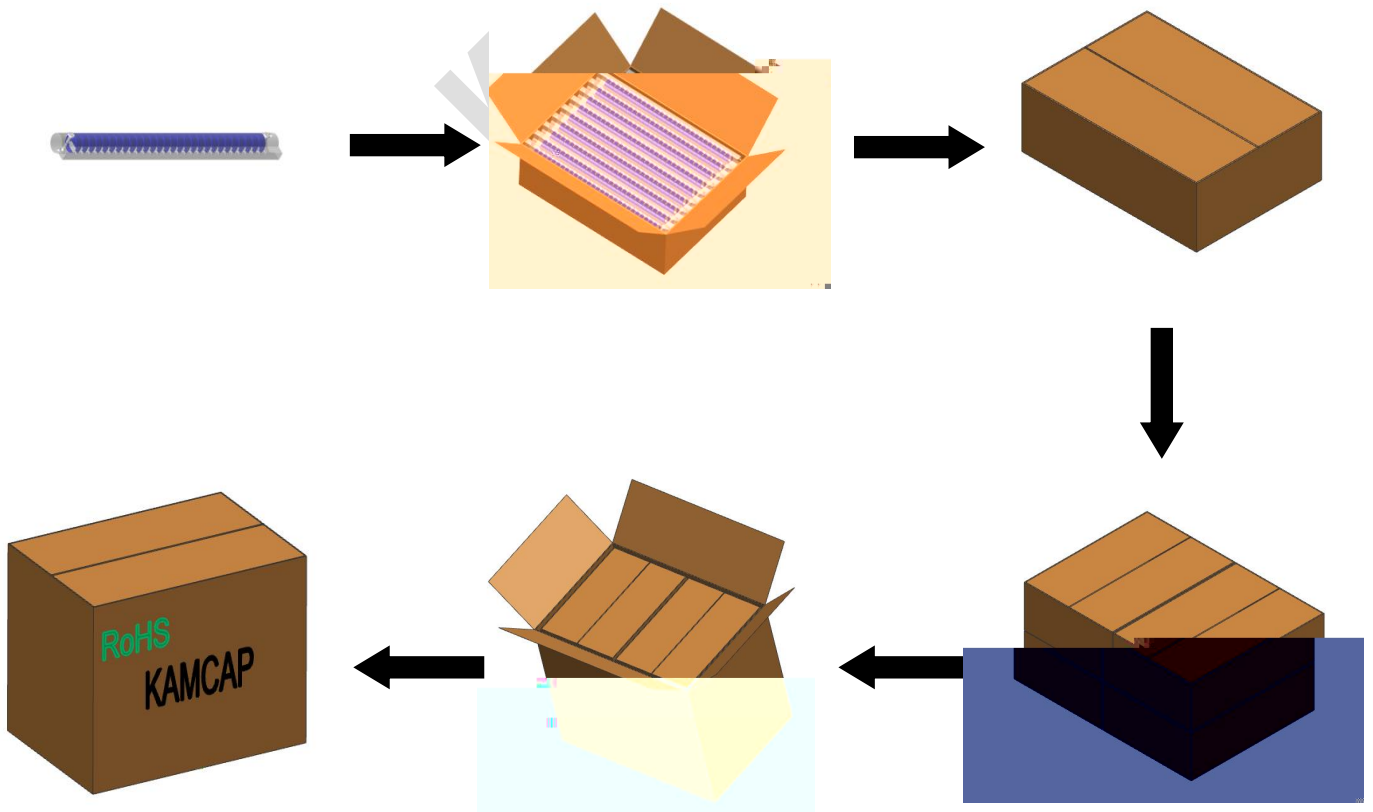
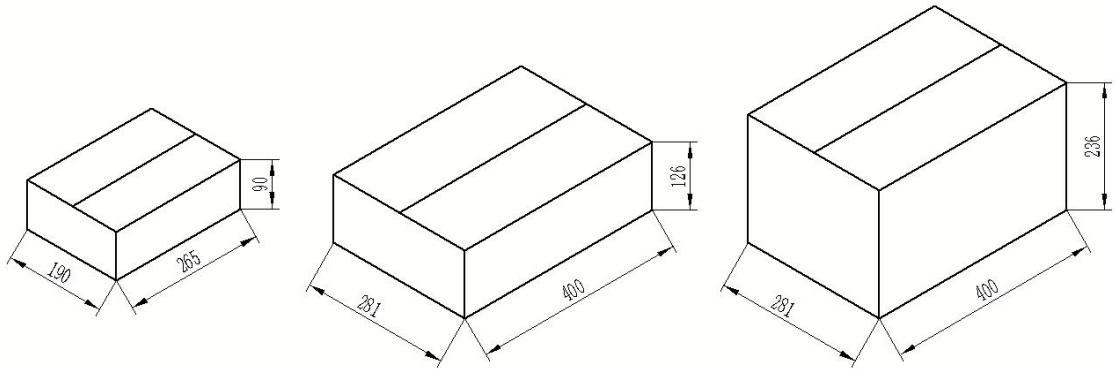

/
C a
c e /c
a e

(A)
(V)
S
C_x

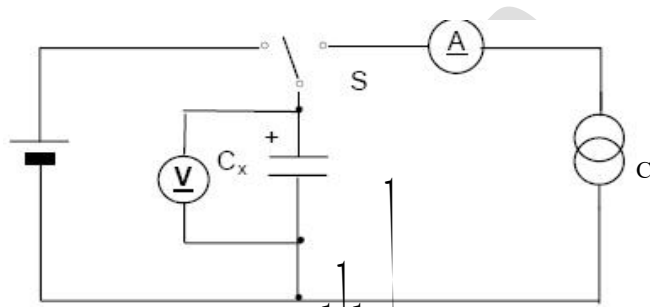

C a c e D c a e d e

F e l c f c a c e d c a e e

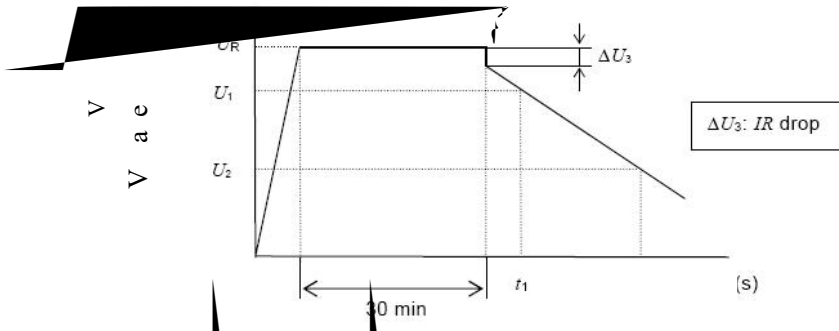

F e 2 a e c a c c b e e e c a a c e a

$$C = \frac{I \times (t_2 - t_1)}{U_1 - U_2}$$

t_2



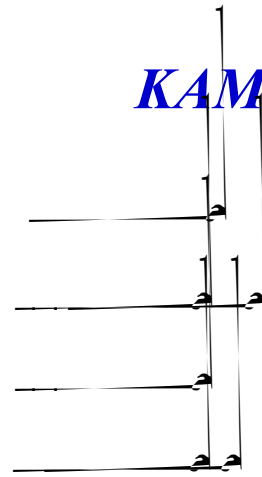
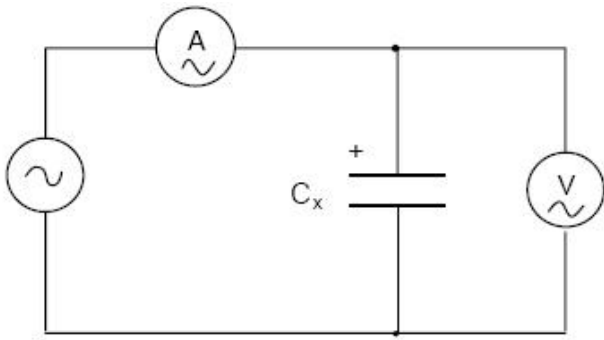

F

$$R_a = \frac{U}{I}$$

Ra

U

I

KAMCAP

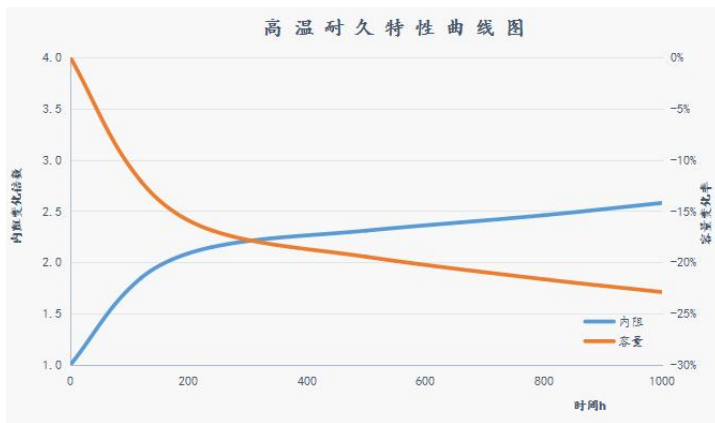
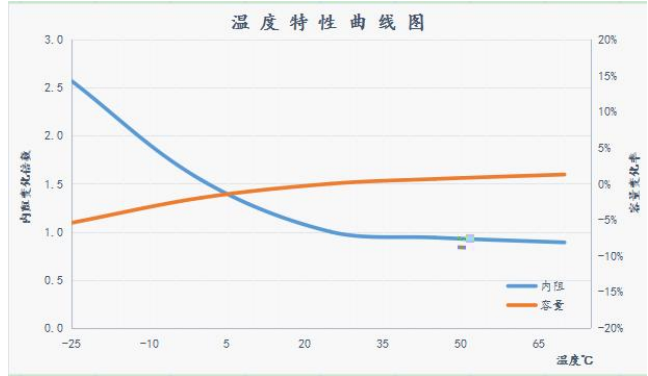
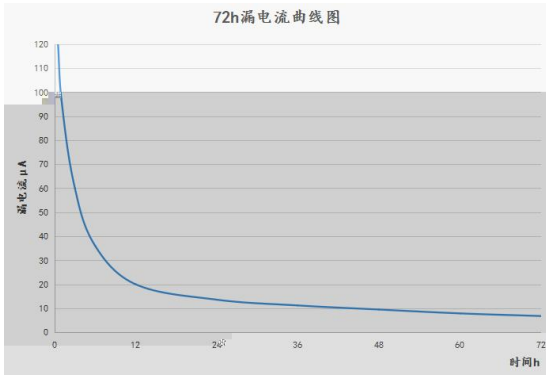

KAMCAP

KAMCAP®

KAMCAP



KAMCAP