

Fea e :

A lica i :

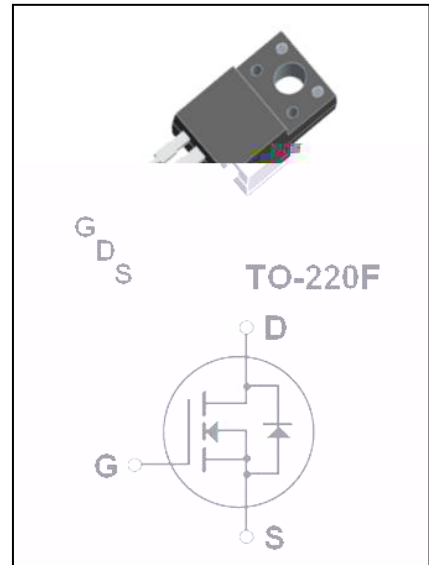

Ab l e Ma im m Ra i g °

		°	
		°	
		±	
		° )	
			°
			°
			°

\*

The mal Cha ac e i ic

			°
			°

**Electrical Characteristics**

<b>Off Characteristics</b>						
△		○				○
△		○				
<b>On Characteristics</b>						
<b>Dynamic Characteristics</b>						
<b>Switching Characteristics</b>						
<b>Thermal Resistance and Maximum Ratings</b>						

、  
、  
、  
、  
、  
、

○ ○  
○

**O -Regi Cha ac e i ic**

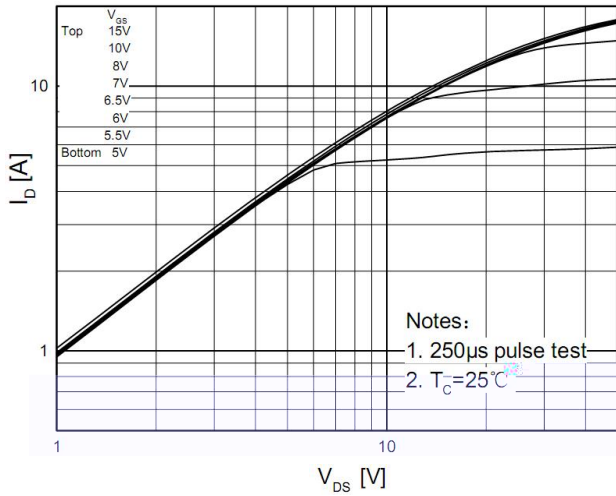

**T a fe Cha ac e i ic**

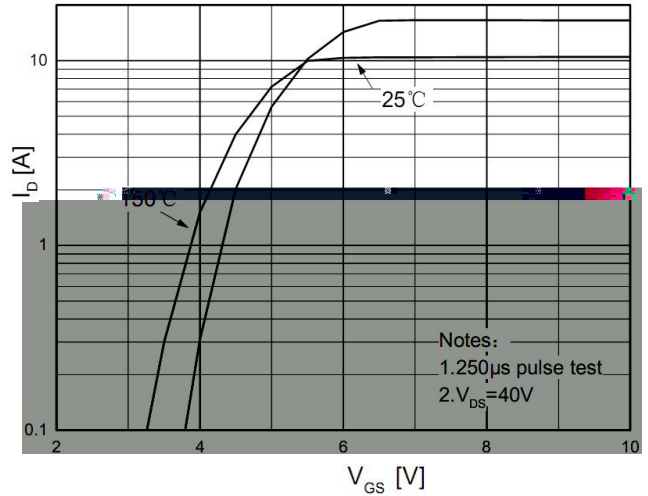

**O -Re i a ce Va ia i .  
D ai C e a d Ga e V I age**

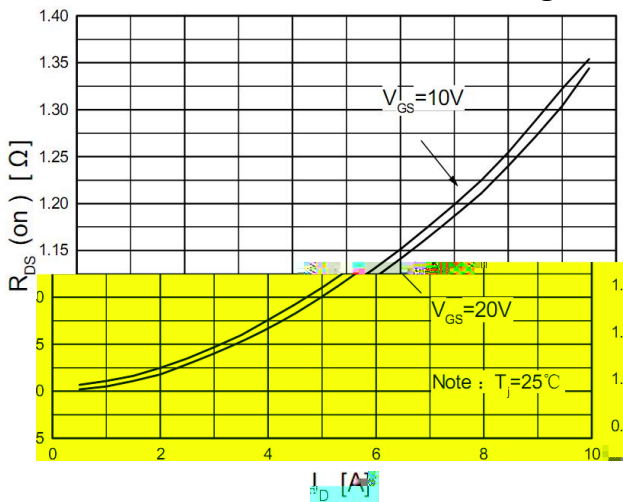

**B d Di de F a d V I age Va ia i .  
. S ce C e a d Tem e a e**

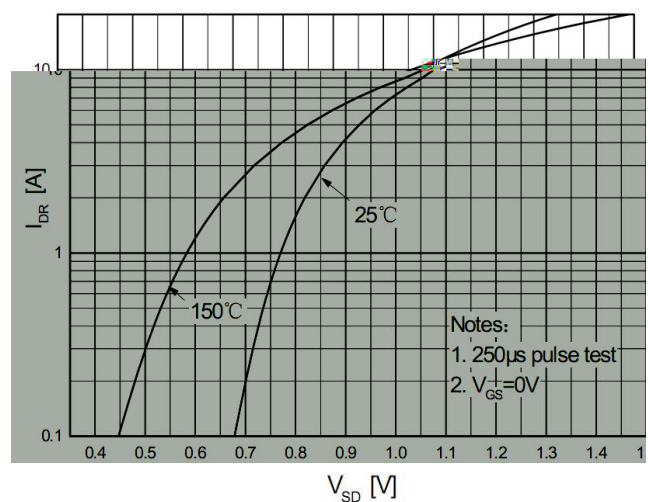

**Ca aci a ce Cha ac e i ic**

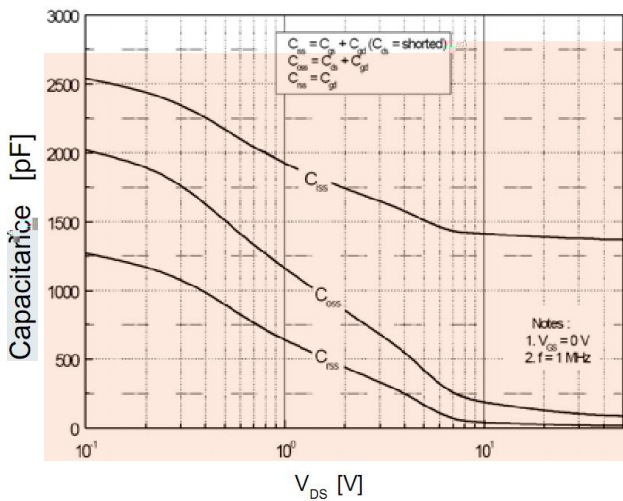

**Ga e Cha ge Cha ac e i ic**

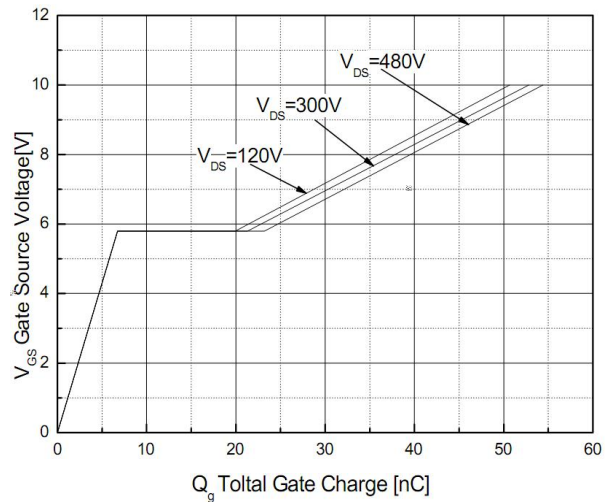

**Breakdown Voltage Variation with Temperature**

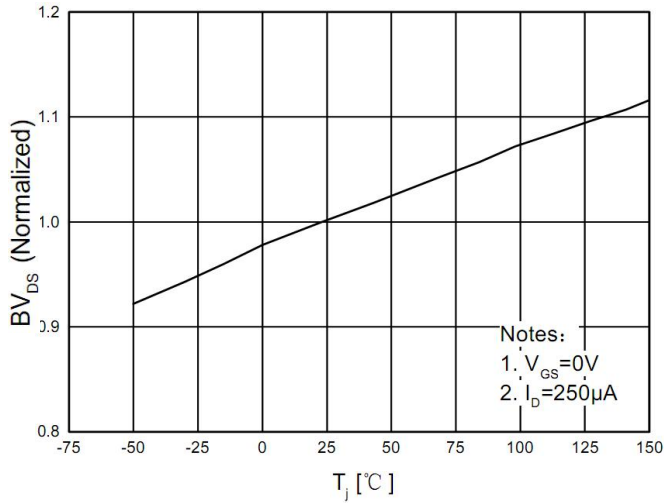

**On-Resistance Variation with Temperature**

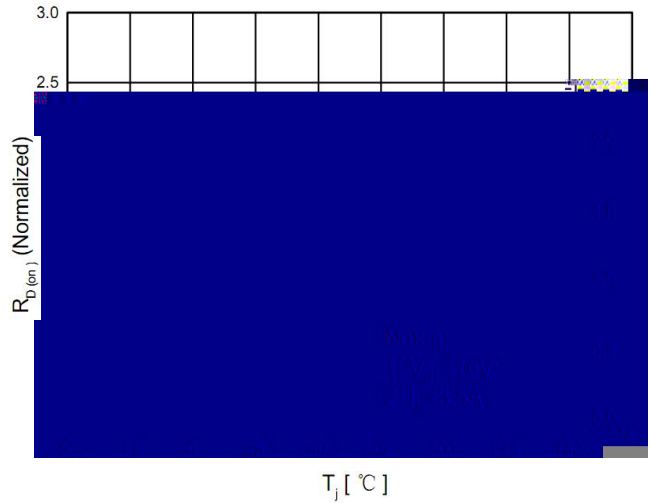

**Maximum Safe Operating Area**

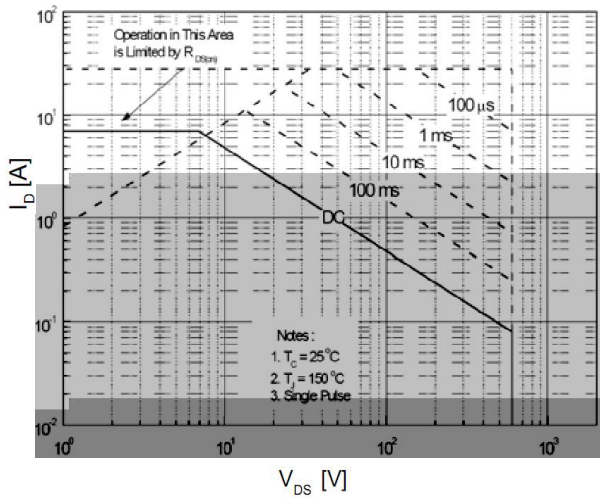

**Maximum Drain Current vs. Case Temperature**

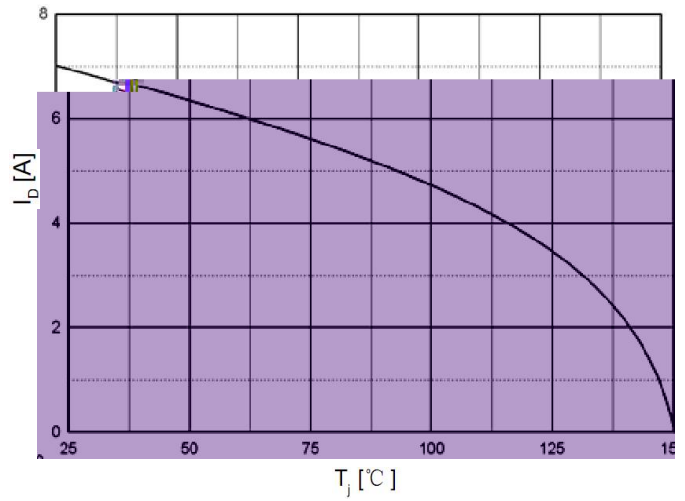

# TO-220F Package Dimensions

			× °
			°\$

