一级代理商：

深圳市弗瑞鑫电子有限公司

地址：深圳市宝安区西乡大道302号金源商务大厦B座三楼

0 -
0 - 0 0
.frxele

1.



2.

3.

4.

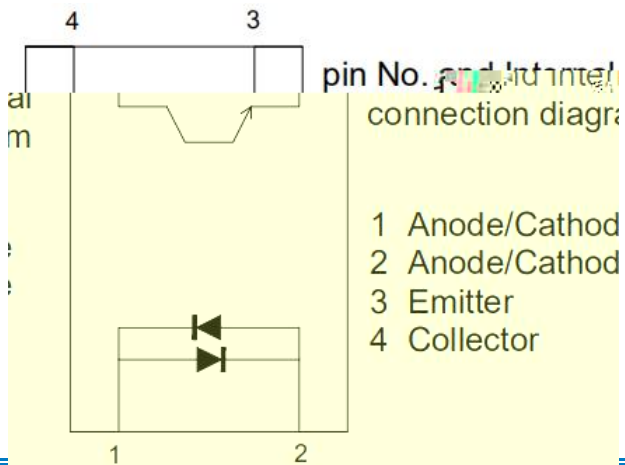

5.

~~ORIENT~~

6.

7.

8.

9.

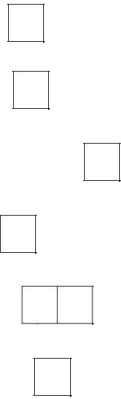
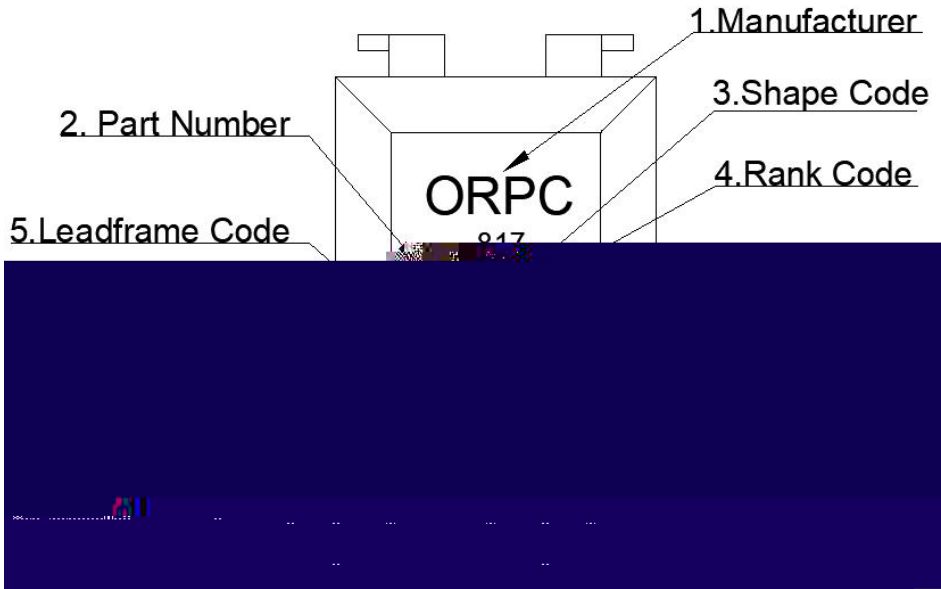

10.

1.

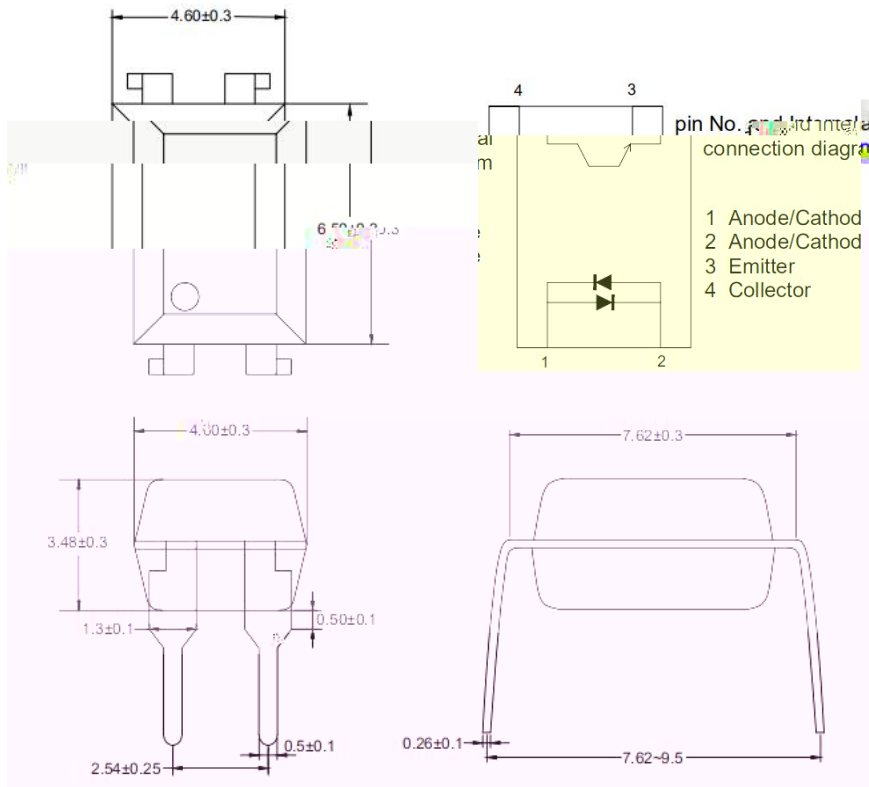

2.

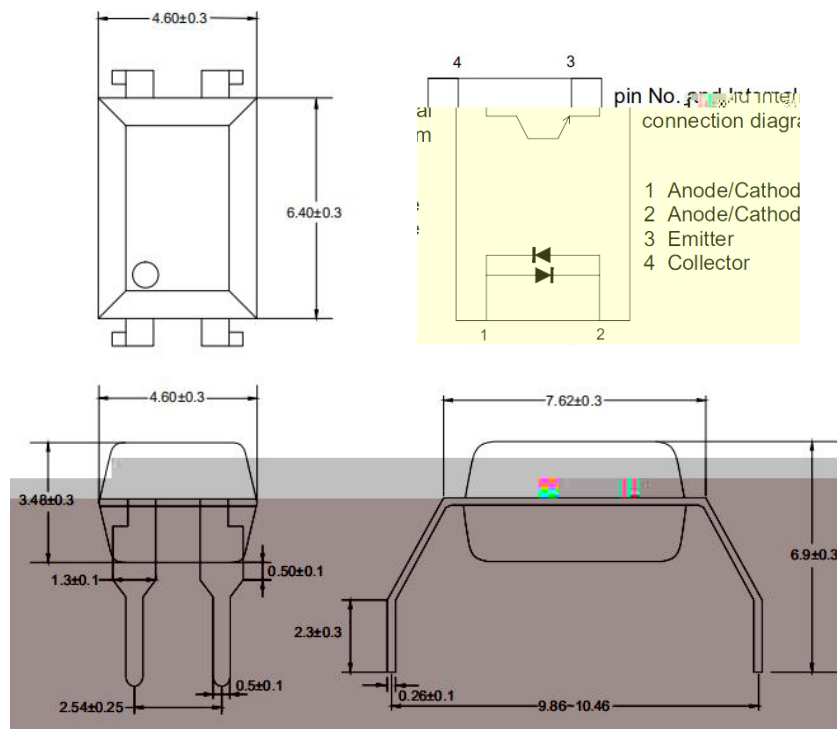

3.

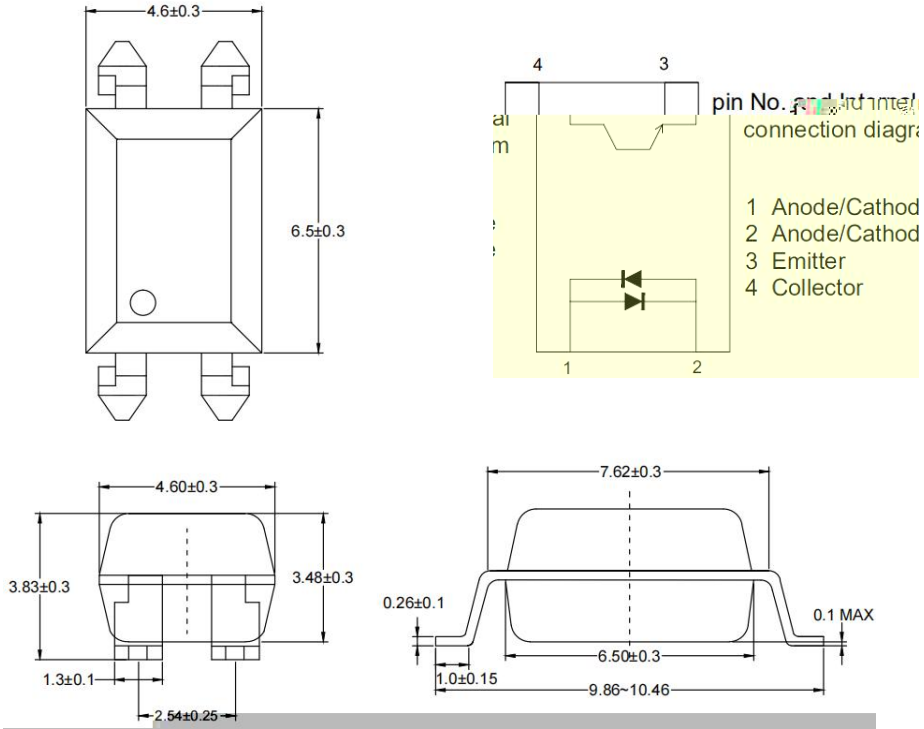

11.

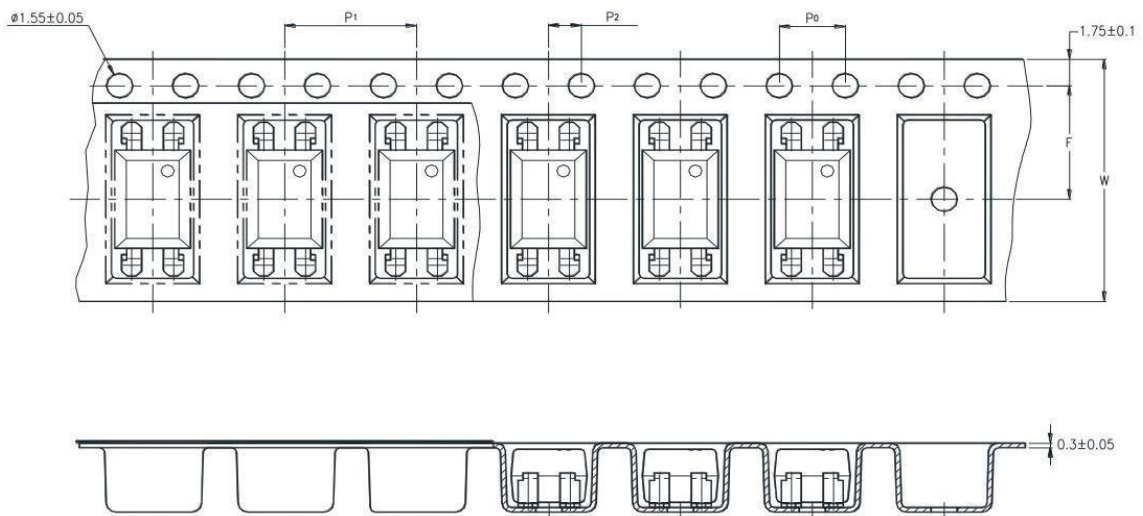

' LMDF

12.

14.

15.

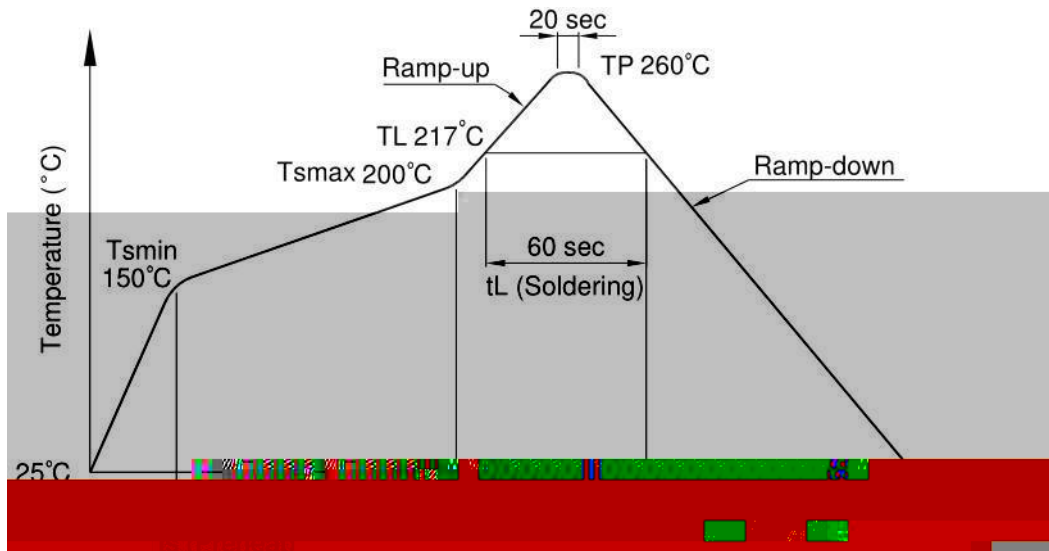

300



Temperature	380+0/-5°C
Time	3 sec max

16.

Fig.1 Forward current vs Ambient temperature

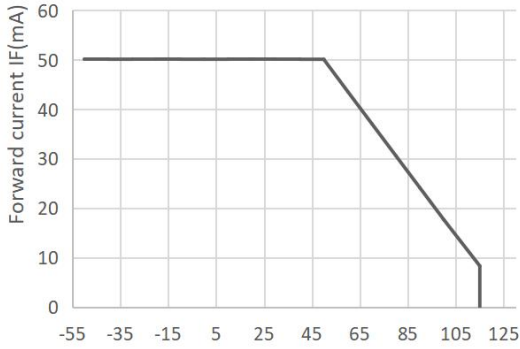

Fig.2 Collector Power Dissipation vs. Ambient temperature

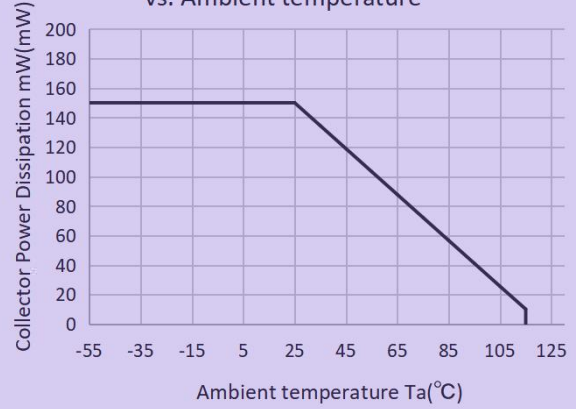

Fig.3 Collector-emitter Saturation Voltage vs. Forward Current

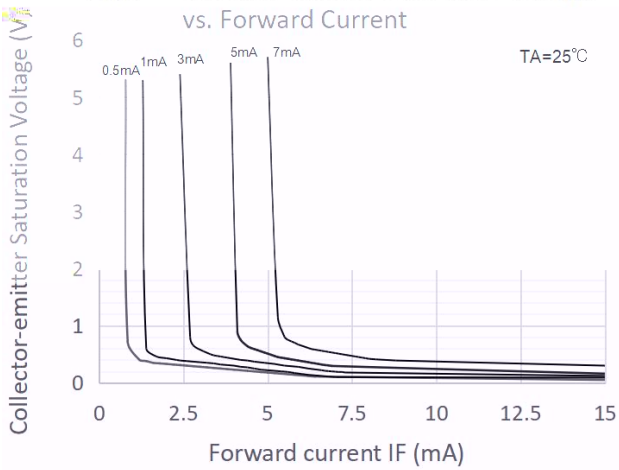

Fig.4 Forward Current vs. Forward Voltage

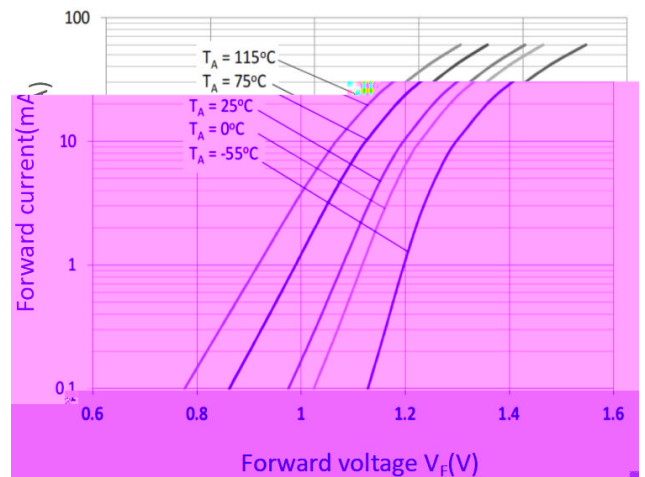

Fig.5 Forward Current vs. Current Transfer Ratio

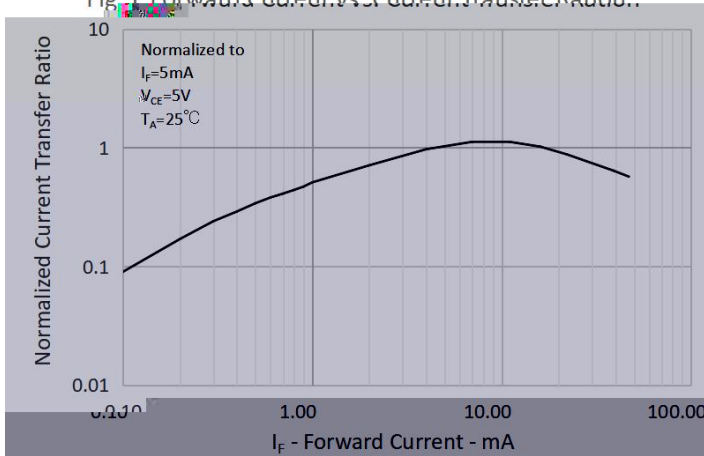

Fig.6 Collector Current vs. Collector-emitter Voltage

